

GTIP60 ISO  
GT Series, Inch Pounds - 60 Hz  
GT010-070 (iso)  
Spec Guide  
Drawings  
Spec Sheets  
Low Temp Heating  
P/T Charts

Rev: 5-05 Rev 1



# GUIDE SPECIFICATIONS

## GT Series 3/4-6 Ton Single Circuit

### GENERAL

Units shall be performance certified to ISO standard 13256-1 for Water Loop Heat Pump, Ground Water Heat Pump and Ground Loop Heat Pump applications. Units shall be Underwriter Laboratories (UL and ULc) listed for safety on all models. Each unit shall be run tested at the factory. Each unit shall be pallet mounted and stretch wrapped.

The units shall be warranted by the manufacturer against defects in materials and workmanship for a period of one year on all parts, and 5 years on the compressor.

The units shall be designed to operate with entering fluid temperatures between 50°F (10°C) and 110°F (43.3°C) in cooling and temperatures between 25°F (-3.9°C) and 80°F (27°C) in heating as manufactured by GeoExcel.

### CASING & CABINET

The cabinet shall be fabricated from heavy-gauge "paint-grip" galvanized steel and finished with two coats of lacquer acrylic. The interior shall be insulated with ½" (12.7mm) thick, multi density, coated, glass fiber. All units shall allow sufficient service access to replace the compressor without unit removal. One blower and two compressor compartment access panels shall be removable with supply and return ductwork in place. A duct collar shall be provided on the supply air opening. A filter rack with 1" (25.4mm) thick disposable filters and a 1" (25.4mm) return air duct collar shall be provided with each unit. The units shall have an insulated divider panel between the air handling section and the compressor section to minimize the transmission of compressor noise, and to permit service testing without air bypass. Units shall have a stainless steel condensate drain pan.

### REFRIGERATION CIRCUITS

All units shall contain a sealed refrigerant circuit including a hermetic compressor, bi-directional thermal expansion valve metering device, finned tube air-to-refrigerant heat exchanger, refrigerant reversing valve and service ports. Compressor shall be high efficiency rotary or scroll type, designed for heat pump duty, quiet operation and mounted on rubber vibration isolators. Compressor motors shall be equipped with overload protection. Refrigerant reversing valves shall be pilot operated sliding piston type with replaceable encapsulated magnetic coils energized only during the cooling cycle. The finned tube coil shall be constructed of lanced aluminum fins not exceeding fourteen fins per inch bonded to rifled copper tubes in a staggered pattern not less than three rows deep and have a 450 PSIG (3100 kPa) working pressure. The coaxial water-to-refrigerant heat exchanger shall be constructed of a convoluted copper (optional cupronickel) inner tube and steel outer tube with a designed refrigerant working pressure of 450 PSIG (3100 kPa) and a designed water side working pressure of no less than 400 PSIG (2750 kPa). The water-to-refrigerant heat exchanger shall be insulated to prevent condensation at low fluid temperatures.

### FAN MOTOR & ASSEMBLY

The fan shall be direct drive centrifugal forward curved type with a dynamically balanced wheel. The housing and wheel shall be designed for quiet low velocity operation and shall be provided with a removable inlet ring. The fan housing shall be removable from the unit without disconnecting the supply air ductwork for servicing of the fan motor. The fan motor shall be three speed PSC type. The motor shall be permanently lubricated and have thermal overload protection.

### ELECTRICAL

Controls and safety devices will be factory wired and mounted within the unit. Controls shall include fan relay, compressor contactor, 24V transformer, reversing valve coil and solid state lock-out controller (CCM). The CCM controller shall include the following features: diagnostic LED's, low pressure bypass time delay (to prevent nuisance low pressure lock-outs during operation with low fluid temperatures), anti short cycle time delay, random start time delay and one time intelligent reset. When the safety controls are activated the lock-out circuit shall reset itself the first time. If the safety controls are subsequently activated, then the lock-out circuit shall disable the compressor until it is reset at the thermostat or main circuit breaker to prevent compressor operation during fault conditions. A lock-out indicating terminal shall be provided in the low voltage circuit. Safety devices include a low pressure cutout set a 20 PSIG (140 kPa) for loss of charge protection (freezestat and/or high discharge gas temperature sensor is not acceptable) and a high pressure cutout control set at 380 PSIG (2600 kPa).

A terminal block with screw terminals shall be provided for control wiring. An optional condensate overflow device shall be factory installed to stop compressor operation if drain pan overflow is imminent. An optional energy management relay to allow unit control by an external source shall be factory installed.

### PIPING

Supply, return water and condensate drain connections shall be brass female pipe thread fittings and mounted flush to cabinet exterior.

### INTERNAL ELECTRIC HEAT

208/230-1-60 volt units shall be equipped with optional factory installed internal electric resistance heat for auxiliary and emergency heat. Electric heater must be Underwriter's Laboratories (UL and ULc) approved for safety when installed in the unit. External heater packages or heater packages not specifically listed for use with the unit are unacceptable. Electric heater packages shall include a heater collar mounted to the blower outlet, individual thermal overload protected heater elements no greater than 5kW each and magnetic contactors. Heater packages shall have a separate power supply connection from the compressor and this power supply shall also power the unit blower motor and control transformer for safe operation.

### HEAT RECOVERY PACKAGE

208/230 volt units shall be equipped with a optional factory installed internal heat recovery kit for domestic hot water production. This kit shall include an internally protected pump, double walled coaxial water-to-refrigerant heat exchanger, 140°F (60°C) hot water temperature limit switch and a fused on/off switch with a power indicator light.

### LOOP PUMP PACKAGE

208/230-1-60 volt units shall be equipped with an optional factory installed ground loop pump kit. This kit shall include a 1/6 HP loop pump, isolation valves and a set of purge connections for purging and pressurizing the ground loop with the unit in place. The pump, all piping and valves shall be internal to the unit.

# GT/GS Series Vertical Dimensions

MODEL	A B C		D E		F G		H		J		K		M		N		P		Q		Condenser Water Connections		Recommended Replacement Nominal Filler Size	
	Width	Depth	Height										R/A Duct Flg Width	R/A Duct Flg Height	Filter Rack Height									
GT010	21.50	21.50	36.25	9.75	11.75	5.88	5.25	5.25	8.00	8.00	14.25	14.25	17.50	14.00	16.00	4.50					3/4" F.P.T.	16 X 20 X 1		
GT/GS018	21.50	21.50	40.25	11.75	13.75	3.75	7.00	5.25	8.00	8.00	14.25	14.25	17.50	18.00	20.00	4.13					3/4" F.P.T.	20 X 20 X 1		
GT/GS024	21.50	21.50	40.25	11.75	13.75	3.75	7.00	5.25	8.00	8.00	14.25	14.25	17.50	16.00	18.00	4.13					3/4" F.P.T.	20 X 20 X 1		
GT/GS030, 036	21.50	26.00	47.25	13.75	15.75	6.13	5.25	5.25	8.00	8.00	15.25	15.25	22.00	22.00	24.00	4.00					3/4" F.P.T.	24 X 24 X 1		
GT/GS042	24.00	32.75	47.25	15.75	15.75	8.38	4.75	5.25	8.00	8.00	16.25	16.25	28.00	22.00	24.00	3.50					1" F.P.T.	24 X 30 X 1		
GT/GS048	24.00	32.75	47.25	15.75	15.75	8.38	5.50	5.25	8.00	8.00	16.25	16.25	28.00	22.00	24.00	4.00					1" F.P.T.	24 X 30 X 1		
GT/GS054	26.00	33.25	51.25	17.75	17.75	7.75	4.25	5.25	8.00	8.00	18.50	18.50	28.00	22.00	24.00	4.00					1" F.P.T.	24 X 30 X 1		
GT/GS062	26.00	33.25	51.25	17.75	17.75	7.13	6.25	5.25	8.00	8.00	18.50	18.50	28.00	22.00	24.00	4.00					1" F.P.T.	24 X 30 X 1		
GT/GS070	26.00	33.25	58.25	17.75	17.75	7.13	6.25	5.25	8.00	8.00	18.50	18.50	28.00	30.00	32.00	4.00					1" F.P.T.	16 X 30 X 1 (2)		

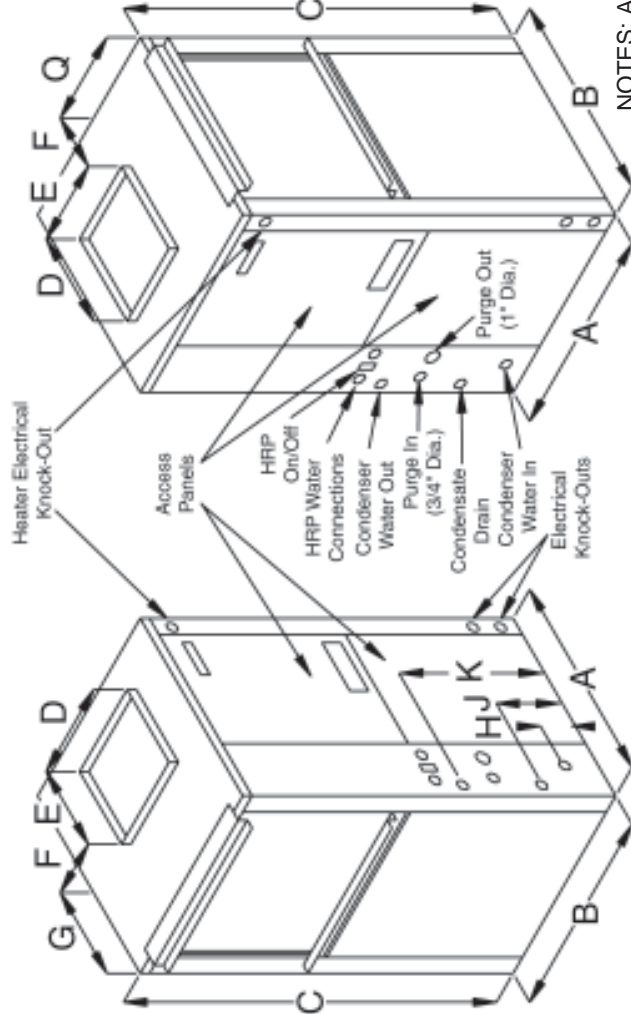

**Left Hand Return (FLT)**

**Right Hand Return (FRT)**

NOTES: All dimensions within +/- 0.125".

All condensate drain connections are 3/4" FPT.

All Heat Recovery Kit connections are 1/2" FPT.

Internal electric heat available on 208-230/1/60 top discharge units only

Internal Loop Heat Pump available on 208-230 volt only.

Internal Heat Recovery Kit available on 208-230 volt only.

Specifications subject to change without notice.

# GT/GS Series Horizontal Dimensions

MODEL	A B C		D	E	F	G	H	J	K	M	N	P	Q	R	T		Condenser Water Connections	Recommended Replacement Nom. Filter Size
	Width	Depth													Height	Filter Rack Height		
GT010	25.50	43.00	21.75	2.00	17.50	23.50	5.25	14.25	7.88	9.75	0.75	11.75	5.88	0.25	16.25	14.25	3/4" F.P.T.	20 X 20 X 1
GT/GS018	25.50	45.00	21.75	2.00	19.25	23.75	5.25	14.25	4.31	11.75	5.00	13.75	4.31	5.00	18.00	16.00	3/4" F.P.T.	20 X 20 X 1
GT/GS024	25.50	43.00	21.75	2.00	20.00	21.00	5.25	14.25	4.31	11.75	5.00	13.75	4.31	5.00	20.50	18.50	3/4" F.P.T.	20 X 20 X 1
GT/GS030,036	26.00	54.50	21.75	2.00	30.00	22.50	5.25	15.25	4.50	13.75	3.00	15.75	4.50	3.00	20.50	18.50	3/4" F.P.T.	18 X 20 X 1 (2)
GT042	30.00	68.00	21.75	2.50	33.50	32.00	5.25	16.25	5.81	15.75	3.00	15.75	5.81	3.00	20.50	18.50	1" F.P.T.	18 X 20 X 1 (2)
GT048	30.00	68.00	21.75	2.50	33.50	32.00	5.25	16.25	5.81	15.75	3.00	15.75	5.81	3.00	20.50	18.50	1" F.P.T.	18 X 20 X 1 (2)
GT054	30.00	68.00	21.75	2.50	33.50	32.00	5.25	18.50	4.81	17.75	2.00	17.75	4.81	2.00	20.50	18.50	1" F.P.T.	18 X 20 X 1 (2)
GT062	30.00	68.00	21.75	2.50	33.50	32.00	5.25	18.50	7.66	17.75	2.00	17.75	7.66	2.00	20.50	18.50	1" F.P.T.	18 X 20 X 1 (2)
GT070	30.00	78.00	21.75	2.50	44.00	31.50	5.25	18.50	7.66	17.75	2.00	17.75	7.66	2.00	20.50	18.50	1" F.P.T.	20 X 24 X 1 (2)

Left Hand Return End Blow (FLE)

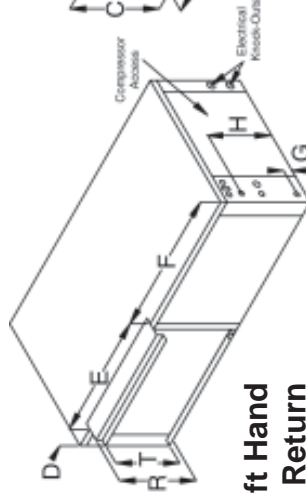

Left Hand Return

Left Hand Return Straight Through (FLS)

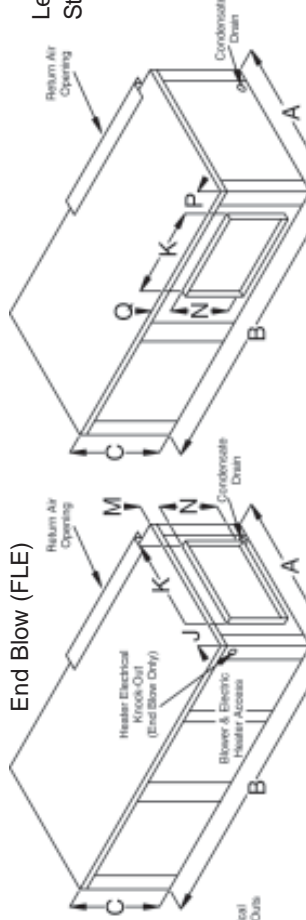

Right Hand Return End Blow (FRE)

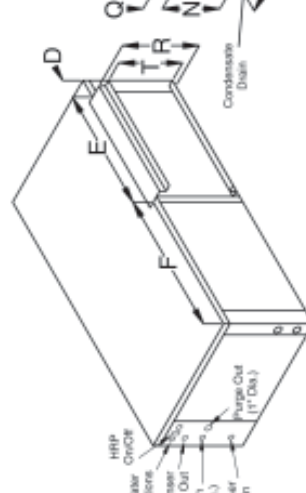

Right Hand Return

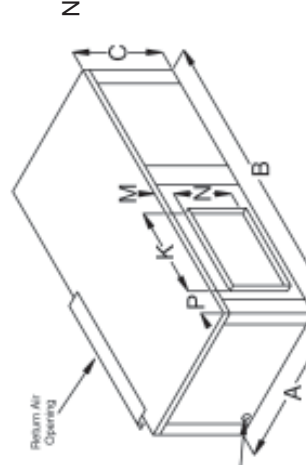

Right Hand Return Straight Through (FRS)

NOTES: All dimensions within +/- 0.125".  
 All condensate drain connections are 3/4" FPT.

All Heat Recovery Kit connections are 1/2" FPT.

Internal electric heat available on 208-230 volt units only

Internal Loop Pump available on 208-230 volt units only.

Internal Heat Recovery Kit available on 208-230 volt units only.

Specifications subject to change without notice.

# GT/GS Series Counterflow Dimensions

MODEL	A		B		C		D		E		F		G		H		J		K		M		N		P		Condenser Water Connections		Recommended Replacement Nominal Filter Size		
	Width	Depth	Height	Blower Opening	Blower Opening	Blower Opening	Blower Opening	Blower Opening	Blower Opening	Blower Opening	Blower Opening	Blower Opening	Blower Opening	Blower Opening	Blower Opening	Blower Opening	Blower Opening	Blower Opening	Blower Opening	Blower Opening	Blower Opening	Blower Opening	Blower Opening	Blower Opening	Blower Opening	Blower Opening	Blower Opening	Blower Opening	Blower Opening	Blower Opening	
GT010	21.50	21.50	36.25	6.50	9.00	7.50	5.50	5.50	15.00	7.00	17.50	14.00	16.00	16.00	16.00	16.00	16.00	16.00	16.00	16.00	16.00	16.00	16.00	16.00	16.00	16.00	16.00	16.00	16.00	16.00	16 X 20 X 1
GT/GS018	21.50	21.50	40.25	9.25	9.63	5.00	5.13	5.50	15.00	10.13	17.50	18.00	20.00	20.00	20.00	20.00	20.00	20.00	20.00	20.00	20.00	20.00	20.00	20.00	20.00	20.00	20.00	20.00	20.00	20.00	20 X 20 X 1
GT/GS024	21.50	21.50	39.25	9.25	9.63	5.00	5.13	6.50	15.50	10.13	17.50	16.00	18.00	18.00	18.00	18.00	18.00	18.00	18.00	18.00	18.00	18.00	18.00	18.00	18.00	18.00	18.00	18.00	18.00	18 X 20 X 1	
GT/GS030_036	21.50	26.00	47.25	9.25	10.25	8.38	5.00	7.00	17.00	9.75	22.00	22.00	24.00	24.00	24.00	24.00	24.00	24.00	24.00	24.00	24.00	24.00	24.00	24.00	24.00	24.00	24.00	24.00	24.00	24 X 24 X 1	
GT/GS042	24.00	32.75	47.25	9.25	10.25	11.63	4.50	7.50	18.50	9.25	28.00	22.00	24.00	24.00	24.00	24.00	24.00	24.00	24.00	24.00	24.00	24.00	24.00	24.00	24.00	24.00	24.00	24.00	24.00	24 X 30 X 1	
GT/GS048	24.00	32.75	47.25	10.75	11.50	10.88	4.50	7.50	18.50	8.75	28.00	22.00	24.00	24.00	24.00	24.00	24.00	24.00	24.00	24.00	24.00	24.00	24.00	24.00	24.00	24.00	24.00	24.00	24.00	24 X 30 X 1	
GT/GS054	26.00	33.25	51.25	10.75	11.50	11.25	5.00	7.00	20.25	9.50	28.00	22.00	24.00	24.00	24.00	24.00	24.00	24.00	24.00	24.00	24.00	24.00	24.00	24.00	24.00	24.00	24.00	24.00	24.00	24 X 30 X 1	
GT/GS062	26.00	33.25	51.25	12.00	12.50	10.63	5.00	7.00	20.25	10.50	28.00	22.00	24.00	24.00	24.00	24.00	24.00	24.00	24.00	24.00	24.00	24.00	24.00	24.00	24.00	24.00	24.00	24.00	24.00	24 X 30 X 1	
G/GST070	26.00	33.25	58.25	12.00	12.50	10.63	5.00	7.00	20.25	10.50	28.00	30.00	32.00	32.00	32.00	32.00	32.00	32.00	32.00	32.00	32.00	32.00	32.00	32.00	32.00	32.00	32.00	32.00	32.00	16 X 30 X 1 (2)	

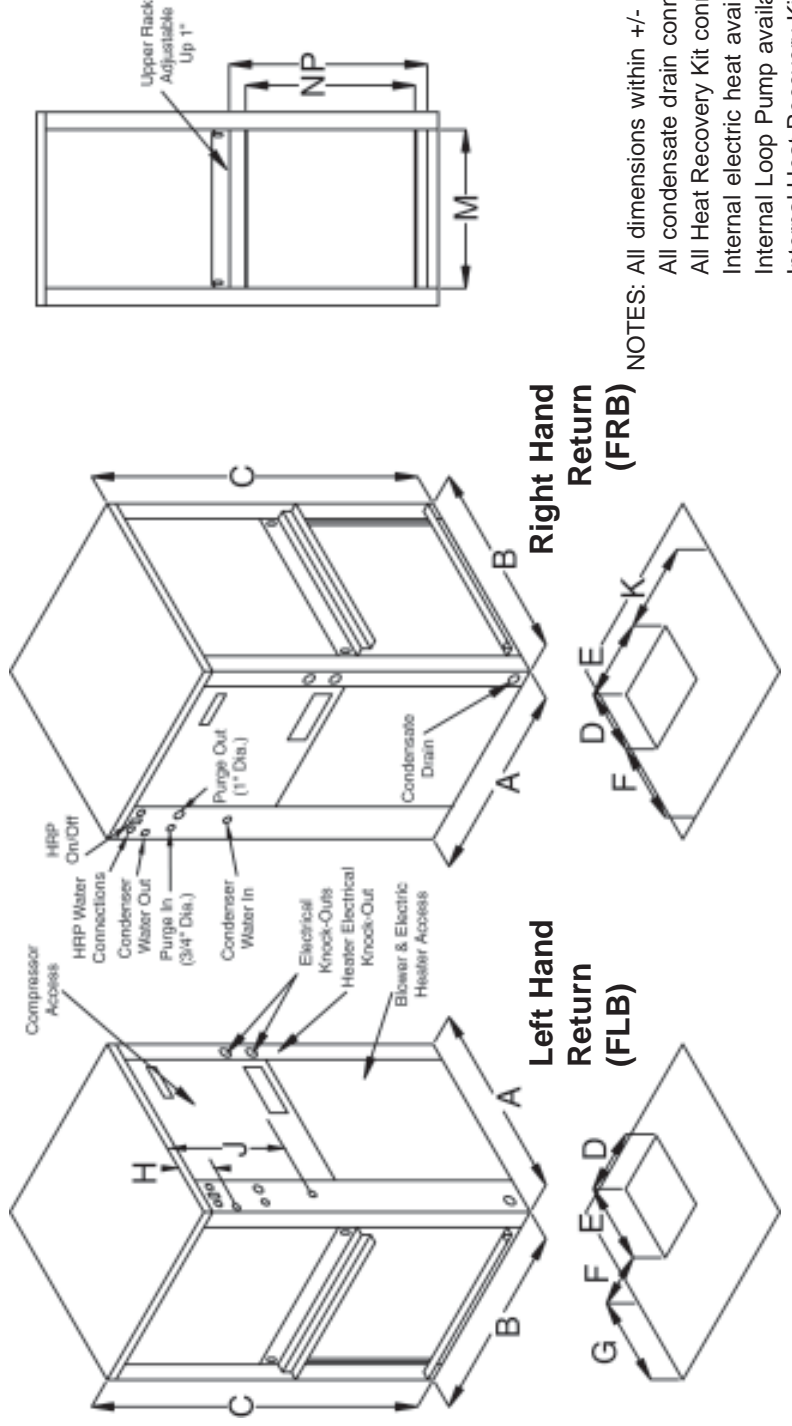

NOTES: All dimensions within +/- 0.125".

All condensate drain connections are 3/4" FPT.

All Heat Recovery Kit connections are 1/2" FPT.

Internal electric heat available on 208-230/1/60 bottom discharge units only

Internal Loop Pump available on 208-230 volt units only.

Internal Heat Recovery Kit available on 208-230 volt units only.

Specifications subject to change without notice.



PACKAGE UNITS

# SPECIFICATION DATA SHEET

LOOP GROUP HIGH-EFFICIENCY WATER SOURCE HEAT PUMPS

# GT010

## ELECTRICAL SPECIFICATIONS

Electrical Characteristics	Elect. Symbol	Compressor		Blower		Loop Pump*		Min. Circuit Amps	Max. Fuse Size
		RLA	LRA	FLA	HP	FLA	HP		
115-1-60	-0	8.3	44.0	2.20	1/10	-	-	12.6	20
208/230-1-60	-1	4.5	35.0	0.96	1/10	1.75	1/6	8.4	15
265-1-60	-2	2.5	16.0	0.85	1/10	-	-	4.0	15

\* Loop pump is a factory installed option on 208/230-1-60 units only.

## MECHANICAL SPECIFICATIONS

Evaporator			
Square Feet	Rows Deep	Tube Size (O.D.)	Fins Per Inch
1.38	3	3/8	14
Blower Size	Weight		
	Net	Ship	
4x7	152	168	

## BLOWER PERFORMANCE

Available External Static Pressure (Inches of Water, Gauge. Wet coil and Filter Included)												
Blower Speed	0.10	0.20	0.30	0.40	0.50	0.60	0.70	0.80	0.90	1.00	1.10	1.20
High	-	-	-	-	405	385	340	280	-	-	-	-
Medium	-	-	-	405	385	345	290	-	-	-	-	-
Low	-	-	400	380	345	300	250	-	-	-	-	-

## CONDENSER WATER FLOW

Water Flow (GPM)	Press. Drop (FOH)
1.0	0.9
1.5	2.0
2.0	3.6
2.5	5.6
3.0	8.1
4.0	14.4

## ISO 13256-1 PERFORMANCE DATA Rated at 350 CFM and 3.0 GPM

Water Loop				Ground Water				Ground Loop			
Cooling		Heating		Cooling		Heating		Cooling		Heating	
Capacity	EER	Capacity	COP	Capacity	EER	Capacity	COP	Capacity	EER	Capacity	COP
10500	14.0	13000	4.7	12000	21.2	10500	4.1	11000	16.1	8300	3.4

## CAPACITY DATA

All performance at 350 CFM and 3.0 GPM

### COOLING EFT Range 45°F to 110°F

Entering Fluid Temp.	Ent. Air Wet Bulb Temp.	Total Capacity BTUH	Watts Input	Heat Rejection BTUH	Sensible Capacity BTUH			EER
					Ent. Air Dry Bulb Temp.	75°	80°	
50°	61°	11215	480	12852	8535	10240	11215	23.4
	64°	11759	490	13432	7984	10136	11242	24.0
	67°	12312	501	14021	7350	9603	11081	24.6
	70°	12874	512	14620	6128	8471	11020	25.2
	73°	13445	523	15228	-	7220	9896	25.7
60°	61°	10852	546	12714	8258	9908	10852	19.9
	64°	11378	558	13281	7726	9808	10877	20.4
	67°	11913	570	13858	7112	9292	10722	20.9
	70°	12457	582	14443	5929	8197	10663	21.4
	73°	13009	595	15038	-	6986	9575	21.9
70°	61°	10522	594	12548	8007	9607	10522	17.7
	64°	11032	607	13103	7491	9510	10547	18.2
	67°	11551	620	13666	6896	9010	10396	18.6
	70°	12078	633	14239	5749	7948	10339	19.1
	73°	12614	647	14821	-	6774	9284	19.5
85°	61°	10191	664	12456	7755	9304	10191	15.3
	64°	10685	679	13001	7255	9211	10215	15.7
	67°	11188	694	13554	6679	8726	10069	16.1
	70°	11698	708	14115	5568	7697	10014	16.5
	73°	12217	723	14686	-	6561	8992	16.9
100°	61°	9839	752	12403	7487	8983	9839	13.1
	64°	10316	768	12937	7005	8892	9862	13.4
	67°	10801	785	13479	6448	8425	9721	13.8
	70°	11294	802	14030	5376	7431	9668	14.1
	73°	11795	819	14589	-	6334	8681	14.4

### HEATING EFT Range 25°F to 80°F

Entering Fluid Temp.	Dry Bulb	Heating Capacity BTUH	Heat of Absorb. BTUH	Power Input Watts	COP
50°	60°	10698	8196	733	4.3
	70°	10147	7598	747	4.0
	80°	9500	6898	763	3.7
60°	60°	12116	9504	766	4.6
	80°	10759	8042	796	4.0
70°	60°	13564	10842	798	5.0
	80°	12045	9213	830	4.3
80°	60°	14966	12133	830	5.3
	70°	14195	11308	846	4.9
	80°	13289	10342	864	4.5



Units are complete packages containing refrigeration compressor, reversing valve, expansion valve metering device and water to refrigerant heat exchanger. Also included are safety controls: Overload protection for motors, high and low refrigerant pressure switches and a solid state lock-out control circuit. Unit finish coated Galvalume. Optional UL approved internal electric heater, factory installed with primary thermal overload protection and magnetic contactors; internal loop pump; and internal heat recovery package (208/230-1-60 only).

Minimum entering fluid temperature with fresh water is 45°F. For lower temperatures, GeoMaster recommends antifreeze protection to at least 20°F below the lowest EFT.

GeoMaster, LLC  
3512 Cavalier Drive  
Fort Wayne, IN 46808  
877-443-6411  
www.geoexcel.com



PACKAGE UNITS

# SPECIFICATION DATA SHEET

LOOP GROUP HIGH-EFFICIENCY WATER SOURCE HEAT PUMPS

# GT018

## ELECTRICAL SPECIFICATIONS

Electrical Characteristics	Elect. Symbol	Compressor		Blower		Loop Pump*		Min. Circuit Amps	Max. Fuse Size
		RLA	LRA	FLA	HP	FLA	HP		
208/230-1-60	-1	5.9	29.0	1.80	1/4	1.75	1/6	11.0	15
265-1-60	-2	5.5	27.0	1.60	1/4	-	-	8.5	15

\* Loop pump is a factory installed option on 208/230-1-60 units only.

## MECHANICAL SPECIFICATIONS

Evaporator			
Square Feet	Rows Deep	Tube Size (O.D.)	Fins Per Inch
2.3	3	3/8	14
Blower Size		Weight	
9x7		Net	Ship
		170	181

## BLOWER PERFORMANCE

Available External Static Pressure (Inches of Water, Gauge. Wet coil and Filter Included)												
Blower Speed	0.10	0.20	0.30	0.40	0.50	0.60	0.70	0.80	0.90	1.00	1.10	1.20
High	-	-	-	750	720	640	510	460	-	-	-	-
Medium	-	-	750	720	650	530	480	-	-	-	-	-
Low	760	730	670	555	490	420	-	-	-	-	-	-

## CONDENSER WATER FLOW

Water Flow (GPM)	Press. Drop (FOH)
1.5	0.7
2.0	1.2
3.0	2.7
4.0	4.7
5.0	7.4
6.0	10.6

## ISO 13256-1 PERFORMANCE DATA Rated at 550 CFM and 4.0 GPM

Water Loop				Ground Water				Ground Loop			
Cooling		Heating		Cooling		Heating		Cooling		Heating	
Capacity	EER	Capacity	COP	Capacity	EER	Capacity	COP	Capacity	EER	Capacity	COP
15500	16.0	16300	5.0	17200	24.0	13200	4.4	16000	18.3	10600	3.7



## CAPACITY DATA

All performance at 550 CFM and 4.0 GPM

### COOLING EFT Range 45°F to 110°F

Entering Fluid Temp.	Ent. Air Wet Bulb Temp.	Total Capacity BTUH	Watts Input	Heat Rejection BTUH	Sensible Capacity BTUH			EER
					75°	80°	85°	
50°	61°	18259	713	20692	13895	16670	18259	25.6
	64°	19144	729	21632	12999	16502	18302	26.3
	67°	20044	745	22586	11966	15634	18040	26.9
	70°	20959	761	23556	9976	13791	17941	27.5
	73°	21889	777	24541	-	11754	16110	28.2
60°	61°	17375	776	20021	13222	15863	17375	22.4
	64°	18217	793	20922	12370	15703	17416	23.0
	67°	19074	810	21838	11387	14878	17167	23.5
	70°	19945	827	22768	9494	13124	17073	24.1
	73°	20830	845	23713	-	11186	15331	24.7
70°	61°	16464	852	19372	12529	15032	16464	19.3
	64°	17262	871	20234	11721	14880	16503	19.8
	67°	18074	890	21111	10790	14098	16267	20.3
	70°	18899	909	22001	8996	12436	16178	20.8
	73°	19738	928	22905	-	10599	14527	21.3
85°	61°	14701	994	18091	11187	13422	14701	14.8
	64°	15413	1016	18879	10466	13286	14735	15.2
	67°	16138	1038	19680	9634	12588	14524	15.5
	70°	16875	1060	20493	8032	11104	14445	15.9
	73°	17623	1083	21318	-	9464	12971	16.3
100°	61°	13318	1125	17156	10135	12159	13318	11.8
	64°	13963	1150	17887	9481	12037	13349	12.1
	67°	14620	1175	18629	8728	11404	13158	12.4
	70°	15287	1200	19383	7277	10059	13086	12.7
	73°	15966	1226	20148	-	8574	11751	13.0



### HEATING EFT Range 25°F to 80°F

Entering Fluid Temp.	Dry Bulb	Heating Capacity BTUH	Heat of Absorb. BTUH	Power Input Watts	COP
50°	60°	15909	12544	986	4.7
	70°	15090	11661	1005	4.4
	80°	14127	10627	1026	4.0
60°	60°	17926	14440	1022	5.1
	80°	15918	12292	1063	4.4
70°	60°	19943	16340	1056	5.5
	80°	17709	13961	1098	4.7
80°	60°	21955	18235	1090	5.9
	70°	20825	17034	1111	5.5
	80°	19496	15626	1134	5.0

Units are complete packages containing refrigeration compressor, reversing valve, expansion valve metering device and water to refrigerant heat exchanger. Also included are safety controls: Overload protection for motors, high and low refrigerant pressure switches and a solid state lock-out control circuit. Unit finish coated Galvalume. Optional UL approved internal electric heater, factory installed with primary thermal overload protection and magnetic contactors; internal loop pump; and internal heat recovery package (208/230-1-60 only).

Minimum entering fluid temperature with fresh water is 45°F. For lower temperatures, GeoMaster recommends antifreeze protection to at least 20°F below the lowest EFT.

GeoMaster, LLC  
 3512 Cavalier Drive  
 Fort Wayne, IN 46808  
 877-443-6411  
 www.geoexcel.com



PACKAGE UNITS

# SPECIFICATION DATA SHEET

LOOP GROUP HIGH-EFFICIENCY WATER SOURCE HEAT PUMPS

# GT024

## ELECTRICAL SPECIFICATIONS

Electrical Characteristics	Elect. Symbol	Compressor		Blower		Loop Pump*		Min. Circuit Amps	Max. Fuse Size
		RLA	LRA	FLA	HP	FLA	HP		
208/230-1-60	-1	10.3	56.0	1.80	1/4	1.75	1/6	16.5	20
265-1-60	-2	8.7	47.0	1.60	1/4	-	-	12.5	15
208/230-3-60	-3	7.1	45.0	1.80	1/4	-	-	10.7	15
460-3-60	-4	3.5	22.4	0.90	1/4	-	-	5.3	15

\* Loop pump is a factory installed option on 208/230-1-60 units only.

## MECHANICAL SPECIFICATIONS

Evaporator			
Square Feet	Rows Deep	Tube Size (O.D.)	Fins Per Inch
2.12	3	3/8	13
Blower Size	Weight		
	Net	Ship	
9x7	174	185	

## BLOWER PERFORMANCE

Available External Static Pressure (Inches of Water, Gauge. Wet coil and Filter Included)												
Blower Speed	0.10	0.20	0.30	0.40	0.50	0.60	0.70	0.80	0.90	1.00	1.10	1.20
High	900	850	800	760	710	690	680	670	-	-	-	-
Medium	750	720	690	670	-	-	-	-	-	-	-	-
Low	670	-	-	-	-	-	-	-	-	-	-	-

## CONDENSER WATER FLOW

Water Flow (GPM)	Press. Drop (FOH)
2.0	0.5
3.0	1.2
4.0	2.1
6.0	4.4
8.0	7.2
10.0	10.6

## ISO 13256-1 PERFORMANCE DATA Rated at 800 CFM and 5.0 GPM

Water Loop				Ground Water				Ground Loop			
Cooling		Heating		Cooling		Heating		Cooling		Heating	
Capacity	EER	Capacity	COP	Capacity	EER	Capacity	COP	Capacity	EER	Capacity	COP
23500	14.2	28500	4.6	26400	21.0	23200	4.1	24500	16.2	18200	3.5



## CAPACITY DATA

All performance at 800 CFM and 5 GPM

### COOLING EFT Range 45°F to 110°F

Entering Fluid Temp.	Ent. Air Wet Bulb Temp.	Total Capacity BTUH	Watts Input	Heat Rejection BTUH	Sensible Capacity BTUH			EER
					Ent. Air Dry Bulb Temp.	75°	80°	
50°	61°	25073	1180	29101	19081	22892	25073	21.2
	64°	26289	1207	30406	17850	22661	25132	21.8
	67°	27525	1233	31732	16432	21469	24772	22.3
	70°	28781	1260	33079	13700	18938	24637	22.9
	73°	30058	1286	34447	-	16141	22123	23.4
60°	61°	24069	1318	28567	18316	21975	24069	18.3
	64°	25236	1348	29834	17135	21753	24125	18.7
	67°	26422	1377	31120	15774	20609	23780	19.2
	70°	27628	1407	32428	13151	18179	23650	19.6
	73°	28854	1436	33755	-	15495	21237	20.1
70°	61°	23064	1456	28033	17552	21058	23064	15.8
	64°	24182	1489	29261	16420	20845	23118	16.2
	67°	25319	1521	30509	15116	19749	22788	16.6
	70°	26475	1554	31777	12602	17421	22663	17.0
	73°	27650	1587	33064	-	14848	20350	17.4
85°	61°	21558	1663	27232	16405	19682	21558	13.0
	64°	22603	1700	28403	15347	19484	21608	13.3
	67°	23666	1737	29592	14128	18459	21299	13.6
	70°	24746	1774	30800	11779	16283	21182	13.9
	73°	25844	1812	32026	-	13878	19021	14.3
100°	61°	20051	1870	26431	15259	18307	20051	10.7
	64°	21023	1911	27544	14275	18122	20098	11.0
	67°	22012	1953	28675	13141	17169	19810	11.3
	70°	23016	1995	29823	10956	15145	19702	11.5
	73°	24038	2037	30989	-	12908	17692	11.8

### HEATING EFT Range 25°F to 80°F

Entering Fluid Temp.	Dry Bulb	Heating Capacity BTUH	Heat of Absorb. BTUH	Power Input Watts	COP
50°	60°	25734	19662	1779	4.2
	70°	24409	18223	1813	3.9
	80°	22851	16536	1851	3.6
60°	60°	28820	22514	1848	4.6
	80°	27336	20911	1883	4.3
70°	60°	31906	25365	1917	4.9
	80°	30263	23598	1953	4.5
80°	60°	28332	21528	1994	4.2
	70°	34992	28216	1986	5.2
	80°	33191	26286	2024	4.8
		31073	24024	2066	4.4



Units are complete packages containing refrigeration compressor, reversing valve, expansion valve metering device and water to refrigerant heat exchanger. Also included are safety controls: Overload protection for motors, high and low refrigerant pressure switches and a solid state lock-out control circuit. Unit finish coated Galvalume. Optional UL approved internal electric heater, factory installed with primary thermal overload protection and magnetic contactors; internal loop pump; and internal heat recovery package (208/230-1-60 only).

Minimum entering fluid temperature with fresh water is 45°F. For lower temperatures, GeoMaster recommends antifreeze protection to at least 20°F below the lowest EFT.

GeoMaster, LLC  
3512 Cavalier Drive  
Fort Wayne, IN 46808  
877-443-6411  
www.geoexcel.com

**ELECTRICAL SPECIFICATIONS**

Electrical Characteristics	Elect. Symbol	Compressor		Blower		Loop Pump*		Min. Circuit Amps	Max. Fuse Size
		RLA	LRA	FLA	HP	FLA	HP		
208/230-1-60	-1	10.3	56.0	1.80	1/4	1.75	1/6	16.4	20
265-1-60	-2	8.7	47.0	1.60	1/4	-	-	12.5	20
208/230-3-60	-3	7.1	45.0	1.80	1/4	-	-	10.7	15
460-3-60	-4	3.5	22.4	0.90	1/4	-	-	5.3	15

\* Loop pump is a factory installed option on 208/230-1-60 units only.

**MECHANICAL SPECIFICATIONS**

Evaporator			
Square Feet	Rows Deep	Tube Size (O.D.)	Fins Per Inch
3.5	3	3/8	14
Blower Size	Weight		
	Net	Ship	
9x7	231	251	

**BLOWER PERFORMANCE**

Available External Static Pressure (Inches of Water, Gauge. Wet coil and Filter Included)												
Blower Speed	0.10	0.20	0.30	0.40	0.50	0.60	0.70	0.80	0.90	1.00	1.10	1.20
High	1275	1210	1140	1060	980	900	820	720	-	-	-	-
Medium	1040	1010	970	920	860	790	730	-	-	-	-	-
Low	950	930	900	860	810	750	-	-	-	-	-	-

**CONDENSER WATER FLOW**

Water Flow (GPM)	Press. Drop (FOH)
3.0	1.2
4.0	2.1
6.0	4.4
8.0	7.2
10.0	10.6
12.0	14.8

**ISO 13256-1 PERFORMANCE DATA** Rated at 1000 CFM and 7.5 GPM

Water Loop				Ground Water				Ground Loop			
Cooling		Heating		Cooling		Heating		Cooling		Heating	
Capacity	EER	Capacity	COP	Capacity	EER	Capacity	COP	Capacity	EER	Capacity	COP
28000	16.0	33200	5.7	30000	24.0	26000	4.7	29000	18.5	19000	4.0

**CAPACITY DATA**

All performance at 1000 CFM and 7.5 GPM

**COOLING** EFT Range 45°F to 110°F

Entering Fluid Temp.	Ent. Air Wet Bulb Temp.	Total Capacity BTUH	Watts Input	Heat Rejection BTUH	Sensible Capacity BTUH			EER
					75°	80°	85°	
50°	61°	29514	1209	33639	22460	26946	29514	24.4
	64°	30944	1236	35162	21011	26674	29583	25.0
	67°	32399	1263	36709	19342	25271	29159	25.7
	70°	33878	1290	38280	16126	22292	29000	26.3
	73°	35381	1318	39877	-	19000	26041	26.9
60°	61°	28380	1360	33022	21597	25911	28380	20.9
	64°	29756	1391	34501	20204	25650	28447	21.4
	67°	31155	1421	36003	18599	24301	28039	21.9
	70°	32577	1452	37530	15507	21436	27886	22.4
	73°	34022	1482	39080	-	18270	25041	23.0
70°	61°	27246	1512	32404	20735	24876	27246	18.0
	64°	28567	1545	33840	19397	24625	27310	18.5
	67°	29910	1579	35298	17857	23330	26919	18.9
	70°	31276	1613	36779	14887	20580	26772	19.4
	73°	32664	1647	38284	-	17540	24040	19.8
85°	61°	25546	1739	31478	19441	23324	25546	14.7
	64°	26785	1777	32848	18187	23088	25606	15.1
	67°	28044	1816	34240	16742	21874	25239	15.4
	70°	29324	1855	35654	13958	19295	25101	15.8
	73°	30625	1894	37089	-	16446	22540	16.2
100°	61°	23846	1966	30552	18147	21771	23846	12.1
	64°	25002	2009	31857	16976	21552	23902	12.4
	67°	26177	2053	33182	15628	20418	23560	12.8
	70°	27372	2097	34528	13029	18011	23431	13.1
	73°	28587	2142	35894	-	15351	21040	13.3

**HEATING** EFT Range 25°F to 80°F

Entering Fluid Temp.	Dry Bulb	Heating Capacity BTUH	Heat of Absorb. BTUH	Power Input Watts	COP
50°	60°	28185	22509	1664	5.0
	70°	26734	20951	1695	4.6
	80°	25028	19124	1730	4.2
60°	60°	32272	26380	1727	5.5
	80°	28657	22529	1796	4.7
70°	60°	36358	30251	1790	6.0
	80°	32286	25933	1862	5.1
80°	60°	40445	34121	1853	6.4
	70°	38362	31920	1888	6.0
	80°	35915	29337	1928	5.5



Units are complete packages containing refrigeration compressor, reversing valve, expansion valve metering device and water to refrigerant heat exchanger. Also included are safety controls: Overload protection for motors, high and low refrigerant pressure switches and a solid state lock-out control circuit. Unit finish coated galvalume. Optional UL approved internal electric heater, factory installed with primary thermal overload protection and magnetic contactors; internal loop pump; and internal heat recovery package (208/230-1-60 only).

Minimum entering fluid temperature with fresh water is 45°F. For lower temperatures, GeoMaster recommends antifreeze protection to at least 20°F below the lowest EFT.

GeoMaster, LLC  
3512 Cavalier Drive  
Fort Wayne, IN 46808  
877-443-6411  
www.geoexcel.com



PACKAGE UNITS

# SPECIFICATION DATA SHEET

LOOP GROUP HIGH-EFFICIENCY WATER SOURCE HEAT PUMPS

# GT036

## ELECTRICAL SPECIFICATIONS

Electrical Characteristics	Elect. Symbol	Compressor		Blower		Loop Pump*		Min. Circuit Amps	Max. Fuse Size
		RLA	LRA	FLA	HP	FLA	HP		
208/230-1-60	-1	13.5	72.5	3.9	1/2	1.75	1/6	22.5	30
265-1-60	-2	11.5	61.0	2.3	1/2	-	-	16.7	25
208/230-3-60	-3	9.0	63.0	3.9	1/2	-	-	15.2	20
460-3-60	-4	4.5	31.0	2.0	1/2	-	-	7.6	15

\* Loop pump is a factory installed option on 208/230-1-60 units only.

## MECHANICAL SPECIFICATIONS

Evaporator			
Square Feet	Rows Deep	Tube Size (O.D.)	Fins Per Inch
3.5	3	3/8	14
Blower Size	Weight		
	Net	Ship	
9x7	243	263	

## BLOWER PERFORMANCE

Available External Static Pressure (Inches of Water, Gauge. Wet coil and Filter Included)												
Blower Speed	0.10	0.20	0.30	0.40	0.50	0.60	0.70	0.80	0.90	1.00	1.10	1.20
High	1500	1440	1370	1290	1210	1120	1020	900	-	-	-	-
Medium	1410	1350	1290	1220	1150	1060	960	-	-	-	-	-
Low	1290	1250	1200	1150	1080	1000	-	-	-	-	-	-

## CONDENSER WATER FLOW

Water Flow (GPM)	Press. Drop (FOH)
4.0	2.1
5.0	3.5
7.0	5.8
9.0	8.8
11.0	10.6
13.0	17.3

## ISO 13256-1 PERFORMANCE DATA Rated at 1200 CFM and 9.0 GPM

Water Loop				Ground Water				Ground Loop			
Cooling		Heating		Cooling		Heating		Cooling		Heating	
Capacity	EER	Capacity	COP	Capacity	EER	Capacity	COP	Capacity	EER	Capacity	COP
34000	14.6	40500	5.1	37800	21.5	32400	4.4	35000	17.0	24500	3.5

## CAPACITY DATA

All performance at 1200 CFM and 9.0 GPM

### COOLING EFT Range 45°F to 110°F

Entering Fluid Temp.	Ent. Air Wet Bulb Temp.	Total Capacity BTUH	Watts Input	Heat Rejection BTUH	Sensible Capacity BTUH			EER
					Ent. Air Dry Bulb Temp.	75°	80°	
50°	61°	36204	1598	41656	27552	33055	36204	22.7
	64°	37960	1633	43532	25775	32721	36289	23.2
	67°	39744	1669	45439	23727	31001	35770	23.8
	70°	41559	1705	47376	19782	27346	35574	24.4
	73°	43402	1741	49343	-	23307	31944	24.9
60°	61°	34792	1790	40901	26477	31765	34792	19.4
	64°	36479	1830	42723	24769	31445	34874	19.9
	67°	38194	1870	44574	22802	29791	34375	20.4
	70°	39937	1910	46455	19010	26279	34186	20.9
	73°	41709	1951	48365	-	22398	30698	21.4
70°	61°	33380	1983	40145	25402	30476	33380	16.8
	64°	34998	2027	41913	23764	30168	33458	17.3
	67°	36644	2071	43710	21876	28582	32979	17.7
	70°	38316	2116	45534	18239	25212	32799	18.1
	73°	40016	2160	47387	-	21489	29452	18.5
85°	61°	31261	2271	39011	23790	28542	31261	13.8
	64°	32777	2322	40699	22255	28254	31335	14.1
	67°	34318	2373	42413	20488	26768	30886	14.5
	70°	35884	2424	44154	17081	23612	30717	14.8
	73°	37477	2475	45921	-	20125	27583	15.1
100°	61°	29143	2560	37878	22178	26607	29143	11.4
	64°	30556	2617	39484	20747	26339	29211	11.7
	67°	31992	2674	41116	19099	24954	28793	12.0
	70°	33453	2732	42773	15923	22012	28636	12.2
	73°	34937	2789	44454	-	18761	25714	12.5

### HEATING EFT Range 25°F to 80°F

Entering Fluid Temp.	Dry Bulb	Heating Capacity BTUH	Heat of Absorb. BTUH	Power Input Watts	COP
50°	60°	35156	27477	2250	4.6
	70°	33346	25522	2293	4.3
	80°	31218	23231	2341	3.9
60°	60°	39694	31798	2314	5.0
	80°	37650	29605	2358	4.7
70°	60°	44232	36118	2378	5.5
	80°	41955	33687	2423	5.1
80°	60°	39278	30838	2474	4.7
	70°	48770	40438	2442	5.9
	80°	46259	37770	2488	5.4
	80°	43308	34641	2540	5.0



Units are complete packages containing refrigeration compressor, reversing valve, expansion valve metering device and water to refrigerant heat exchanger. Also included are safety controls: Overload protection for motors, high and low refrigerant pressure switches and a solid state lock-out control circuit. Unit finish coated galvalume. Optional UL approved internal electric heater, factory installed with primary thermal overload protection and magnetic contactors; internal loop pump; and internal heat recovery package (208/230-1-60 only).

Minimum entering fluid temperature with fresh water is 45°F. For lower temperatures, GeoMaster recommends antifreeze protection to at least 20°F below the lowest EFT.

GeoMaster, LLC  
 3512 Cavalier Drive  
 Fort Wayne, IN 46808  
 877-443-6411  
 www.geoexcel.com



PACKAGE UNITS

# SPECIFICATION DATA SHEET

LOOP GROUP HIGH-EFFICIENCY WATER SOURCE HEAT PUMPS

# GT042

## ELECTRICAL SPECIFICATIONS

Electrical Characteristics	Elect. Symbol	Compressor		Blower		Loop Pump*		Min. Circuit Amps	Max. Fuse Size
		RLA	LRA	FLA	HP	FLA	HP		
208/230-1-60	-1	16.0	88.0	3.9	1/2	1.75	1/6	25.7	35
265-1-60	-2	12.8	75.0	2.3	1/2	-	-	18.3	30
208/230-3-60	-3	10.3	77.0	3.9	1/2	-	-	16.8	25
460-3-60	-4	5.1	39.0	2.0	1/2	-	-	8.4	15

\* Loop pump is a factory installed option on 208/230-1-60 units only.

## MECHANICAL SPECIFICATIONS

Evaporator			
Square Feet	Rows Deep	Tube Size (O.D.)	Fins Per Inch
4.5	3	3/8	14
Blower Size	Weight		
	Net	Ship	
9x7	260	280	

## BLOWER PERFORMANCE

Available External Static Pressure (Inches of Water, Gauge. Wet coil and Filter Included)												
Blower Speed	0.10	0.20	0.30	0.40	0.50	0.60	0.70	0.80	0.90	1.00	1.10	1.20
High	-	1570	1500	1420	1330	1260	1190	1100	-	-	-	-
Medium	1560	1520	1450	1380	1290	1140	1000	-	-	-	-	-
Low	1380	1290	1200	1090	980	-	-	-	-	-	-	-

## CONDENSER WATER FLOW

Water Flow (GPM)	Press. Drop (FOH)
4.0	1.1
5.0	1.8
7.0	3.5
9.0	5.7
13.0	12.2
15.0	16.1

## ISO 13256-1 PERFORMANCE DATA Rated at 1400 CFM and 9.0 GPM

Water Loop				Ground Water				Ground Loop			
Cooling		Heating		Cooling		Heating		Cooling		Heating	
Capacity	EER	Capacity	COP	Capacity	EER	Capacity	COP	Capacity	EER	Capacity	COP
39600	14.8	48500	5.3	44000	21.2	39000	4.5	41000	16.6	30000	3.7

## CAPACITY DATA

All performance at 1400 CFM and 9.0 GPM

### COOLING EFT Range 45°F to 110°F

Entering Fluid Temp.	Ent. Air Wet Bulb Temp.	Total Capacity BTUH	Watts Input	Heat Rejection BTUH	Sensible Capacity BTUH			EER
					75°	80°	85°	
50°	61°	41761	1943	48389	31780	38127	41761	21.5
	64°	43785	1986	50560	29730	37743	41859	22.1
	67°	45844	2029	52767	27369	35758	41260	22.6
	70°	47937	2073	55008	22818	31542	41034	23.1
	73°	50063	2117	57285	-	26884	36847	23.7
60°	61°	40218	2151	47559	30606	36719	40218	18.7
	64°	42168	2199	49671	28632	36349	40313	19.2
	67°	44151	2247	51817	26358	34438	39736	19.6
	70°	46166	2295	53998	21975	30377	39518	20.1
	73°	48214	2344	56212	-	25891	35486	20.6
70°	61°	38676	2360	46728	29432	35311	38676	16.4
	64°	40551	2412	48782	27534	34955	38767	16.8
	67°	42458	2465	50868	25347	33117	38212	17.2
	70°	44396	2518	52987	21132	29212	38003	17.6
	73°	46365	2571	55139	-	24898	34125	18.0
85°	61°	36362	2673	45483	27672	33199	36362	13.6
	64°	38125	2732	47448	25887	32864	36448	14.0
	67°	39918	2792	49444	23831	31136	35926	14.3
	70°	41740	2852	51471	19868	27465	35729	14.6
	73°	43592	2913	53529	-	23409	32084	15.0
100°	61°	34049	2986	44237	25911	31086	34049	11.4
	64°	35699	3052	46114	24240	30773	34129	11.7
	67°	37378	3119	48020	22315	29155	33640	12.0
	70°	39084	3186	49955	18604	25717	33456	12.3
	73°	40818	3254	51920	-	21919	30042	12.5

### HEATING EFT Range 25°F to 80°F

Entering Fluid Temp.	Dry Bulb	Heating Capacity BTUH	Heat of Absorb. BTUH	Power Input Watts	COP
50°	60°	42003	33266	2561	4.8
	70°	39840	30938	2609	4.5
	80°	37298	28210	2663	4.1
60°	60°	47380	38408	2629	5.3
	80°	44940	35799	2679	4.9
70°	60°	52756	43551	2698	5.7
	80°	50040	40661	2749	5.3
80°	60°	46847	37272	2806	4.9
	70°	58133	48693	2767	6.2
	80°	55140	45522	2819	5.7
		51622	41803	2878	5.3

Units are complete packages containing refrigeration compressor, reversing valve, expansion valve metering device and water to refrigerant heat exchanger. Also included are safety controls: Overload protection for motors, high and low refrigerant pressure switches and a solid state lock-out control circuit. Unit finish coated galvalume. Optional UL approved internal electric heater, factory installed with primary thermal overload protection and magnetic contactors; internal loop pump; and internal heat recovery package (208/230-1-60 only).

Minimum entering fluid temperature with fresh water is 45°F. For lower temperatures, GeoMaster recommends antifreeze protection to at least 20°F below the lowest EFT.

GeoMaster, LLC  
 3512 Cavalier Drive  
 Fort Wayne, IN 46808  
 877-443-6411  
 www.geoexcel.com





PACKAGE UNITS

# SPECIFICATION DATA SHEET

LOOP GROUP HIGH-EFFICIENCY WATER SOURCE HEAT PUMPS

# GT048

## ELECTRICAL SPECIFICATIONS

Electrical Characteristics	Elect. Symbol	Compressor		Blower		Loop Pump*		Min. Circuit Amps	Max. Fuse Size
		RLA	LRA	FLA	HP	FLA	HP		
208/230-1-60	-1	18.3	109.0	3.9	1/2	1.75	1/6	28.5	45
208/230-3-60	-3	12.4	88.0	3.9	1/2	-	-	19.4	30
460-3-60	-4	6.4	44.0	2.0	1/2	-	-	10.0	15
575-3-60	-5	4.8	34.0	2.6	3/4	-	-	8.6	15

\* Loop pump is a factory installed option on 208/230-1-60 units only.

## MECHANICAL SPECIFICATIONS

Evaporator			
Square Feet	Rows Deep	Tube Size (O.D.)	Fins Per Inch
4.5	3	3/8	14
Blower Size	Weight		
	Net	Ship	
10x8	310	334	

## BLOWER PERFORMANCE

Available External Static Pressure (Inches of Water, Gauge. Wet coil and Filter Included)												
Blower Speed	0.10	0.20	0.30	0.40	0.50	0.60	0.70	0.80	0.90	1.00	1.10	1.20
High	-	1770	1700	1620	1530	1460	1390	1300	1210	-	-	-
Medium	1760	1720	1650	1580	1490	1340	1200	-	-	-	-	-
Low	1580	1490	1400	1290	1180	-	-	-	-	-	-	-

## CONDENSER WATER FLOW

Water Flow (GPM)	Press. Drop (FOH)
4.5	1.4
6.0	2.6
7.0	3.5
9.5	6.4
12.0	10.2
16.0	18.3

## ISO 13256-1 PERFORMANCE DATA Rated at 1600 CFM and 12.0 GPM

Water Loop				Ground Water				Ground Loop			
Cooling		Heating		Cooling		Heating		Cooling		Heating	
Capacity	EER	Capacity	COP	Capacity	EER	Capacity	COP	Capacity	EER	Capacity	COP
47000	13.8	58000	5.0	52000	20.1	47000	4.2	49000	15.8	36500	3.5

## CAPACITY DATA

All performance at 1600 CFM and 12.0 GPM

### COOLING EFT Range 45°F to 110°F

Entering Fluid Temp.	Ent. Air Wet Bulb Temp.	Total Capacity BTUH	Watts Input	Heat Rejection BTUH	Sensible Capacity BTUH			EER
					75°	80°	85°	
50°	61°	49014	2352	57040	37299	44749	49014	20.8
	64°	51390	2405	59594	34894	44298	49129	21.4
	67°	53806	2457	62189	32122	41969	48425	21.9
	70°	56262	2510	64826	26781	37021	48160	22.4
	73°	58758	2563	67504	-	31553	43246	22.9
60°	61°	47369	2645	56395	36048	43248	47369	17.9
	64°	49665	2704	58891	33723	42812	47480	18.4
	67°	52001	2763	61428	31044	40560	46801	18.8
	70°	54374	2822	64005	25882	35778	46544	19.3
	73°	56787	2882	66621	-	30495	41795	19.7
70°	61°	45724	2938	55750	34796	41746	45724	15.6
	64°	47941	3003	58189	32552	41325	45832	16.0
	67°	50195	3069	60667	29967	39152	45176	16.4
	70°	52487	3135	63183	24984	34536	44929	16.7
	73°	54815	3201	65739	-	29436	40344	17.1
85°	61°	43258	3378	54782	32919	39494	43258	12.8
	64°	45355	3453	57135	30796	39096	43359	13.1
	67°	47487	3528	59525	28350	37040	42738	13.5
	70°	49655	3604	61951	23636	32673	42505	13.8
	73°	51858	3680	64415	-	27848	38167	14.1
100°	61°	40791	3817	53815	31042	37242	40791	10.7
	64°	42768	3902	56081	29040	36866	40886	11.0
	67°	44779	3987	58383	26733	34928	40301	11.2
	70°	46823	4073	60719	22288	30810	40081	11.5
	73°	48901	4159	63091	-	26260	35991	11.8

### HEATING EFT Range 25°F to 80°F

Entering Fluid Temp.	Dry Bulb	Heating Capacity BTUH	Heat of Absorb. BTUH	Power Input Watts	COP
50°	60°	50721	39677	3237	4.6
	70°	48109	36857	3298	4.3
	80°	45040	33552	3367	3.9
60°	60°	57065	45660	3343	5.0
	80°	54127	42506	3406	4.7
70°	60°	63410	51643	3449	5.4
	80°	60145	48156	3514	5.0
80°	60°	56308	44068	3587	4.6
	70°	69755	57626	3555	5.8
	80°	66163	53805	3622	5.4
	80°	61942	49325	3698	4.9



Units are complete packages containing refrigeration compressor, reversing valve, expansion valve metering device and water to refrigerant heat exchanger. Also included are safety controls: Overload protection for motors, high and low refrigerant pressure switches and a solid state lock-out control circuit. Unit finish coated galvalume. Optional UL approved internal electric heater, factory installed with primary thermal overload protection and magnetic contactors; internal loop pump; and internal heat recovery package (208/230-1-60 only).

Minimum entering fluid temperature with fresh water is 45°F. For lower temperatures, GeoMaster recommends antifreeze protection to at least 20°F below the lowest EFT.

GeoMaster, LLC  
 3512 Cavalier Drive  
 Fort Wayne, IN 46808  
 877-443-6411  
 www.geoexcel.com



PACKAGE UNITS

## SPECIFICATION DATA SHEET

LOOP GROUP HIGH-EFFICIENCY WATER SOURCE HEAT PUMPS

GT054

## ELECTRICAL SPECIFICATIONS

Electrical Characteristics	Elect. Symbol	Compressor		Blower		Loop Pump*		Min. Circuit Amps	Max. Fuse Size
		RLA	LRA	FLA	HP	FLA	HP		
208/230-1-60	-1	23.7	129.0	5.0	3/4	1.75	1/6	36.4	50
208/230-3-60	-3	14.7	99.0	5.0	3/4	-	-	23.4	35
460-3-60	-4	7.4	49.5	2.5	3/4	-	-	11.8	15
575-3-60	-5	5.6	40.0	2.6	3/4	-	-	9.6	15

\* Loop pump is a factory installed option on 208/230-1-60 units only.

## MECHANICAL SPECIFICATIONS

Evaporator			
Square Feet	Rows Deep	Tube Size (O.D.)	Fins Per Inch
4.5	3	3/8	14
Blower Size	Weight		
	Net	Ship	
10x8	360	385	

## BLOWER PERFORMANCE

Available External Static Pressure (Inches of Water, Gauge. Wet coil and Filter Included)												
Blower Speed	0.10	0.20	0.30	0.40	0.50	0.60	0.70	0.80	0.90	1.00	1.10	1.20
High	1990	1960	1900	1820	1780	1750	1700	1660	1600	1550	-	-
Medium	1940	1910	1850	1770	1740	1710	1660	1620	-	-	-	-
Low	1900	1870	1810	1710	1685	1660	-	-	-	-	-	-

## CONDENSER WATER FLOW

Water Flow (GPM)	Press. Drop (FOH)
5.0	1.2
8.0	3.0
10.0	4.8
12.0	6.9
14.0	9.4
18.0	15.5

## ISO 13256-1 PERFORMANCE DATA Rated at 1800 CFM and 14.0 GPM

Water Loop				Ground Water				Ground Loop			
Cooling		Heating		Cooling		Heating		Cooling		Heating	
Capacity	EER	Capacity	COP	Capacity	EER	Capacity	COP	Capacity	EER	Capacity	COP
51000	13.3	62000	4.4	57000	18.8	52000	4.0	52000	14.6	41000	3.4



## CAPACITY DATA

All performance at 1800 CFM and 14.0 GPM

## COOLING EFT Range 45°F to 110°F

Entering Fluid Temp.	Ent. Air Wet Bulb Temp.	Total Capacity BTUH	Watts Input	Heat Rejection BTUH	Sensible Capacity BTUH			EER
					75°	80°	85°	
50°	61°	58645	2934	68657	44629	53543	58645	20.0
	64°	61488	3000	71722	41750	53003	58783	20.5
	67°	64379	3065	74837	38434	50216	57941	21.0
	70°	67318	3131	78001	32043	44295	57624	21.5
	73°	70305	3197	81214	-	37754	51744	22.0
60°	61°	55663	3126	66329	42360	50821	55663	17.8
	64°	58362	3195	69264	39628	50308	55794	18.3
	67°	61106	3265	72246	36480	47663	54995	18.7
	70°	63895	3335	75275	30414	42043	54694	19.2
	73°	66730	3406	78351	-	35834	49114	19.6
70°	61°	52062	3350	63492	39619	47532	52062	15.5
	64°	54586	3424	66269	37064	47053	52184	15.9
	67°	57152	3499	69091	34120	44579	51437	16.3
	70°	59761	3574	71956	28446	39323	51155	16.7
	73°	62412	3650	74866	-	33515	45936	17.1
85°	61°	46168	3792	59107	35134	42151	46168	12.2
	64°	48406	3876	61632	32868	41726	46276	12.5
	67°	50682	3961	64197	30257	39532	45614	12.8
	70°	52996	4046	66801	25226	34871	45364	13.1
	73°	55347	4132	69445	-	29721	40735	13.4
100°	61°	40770	4218	55163	31026	37223	40770	9.7
	64°	42746	4312	57458	29025	36847	40865	9.9
	67°	44756	4406	59789	26719	34910	40280	10.2
	70°	46799	4501	62156	22276	30794	40060	10.4
	73°	48875	4596	64558	-	26246	35972	10.6

## HEATING EFT Range 25°F to 80°F

Entering Fluid Temp.	Dry Bulb	Heating Capacity BTUH	Heat of Absorb. BTUH	Power Input Watts	COP
50°	60°	57030	43743	3894	4.3
	70°	54094	40555	3968	4.0
	80°	50643	36821	4051	3.7
60°	60°	62922	49225	4014	4.6
	80°	55874	41628	4175	3.9
70°	60°	68869	54764	4134	4.9
	80°	65323	50952	4212	4.5
80°	60°	61155	46484	4300	4.2
	70°	74667	60141	4258	5.1
	80°	70823	56022	4338	4.8
		66304	51194	4429	4.4



Units are complete packages containing refrigeration compressor, reversing valve, expansion valve metering device and water to refrigerant heat exchanger. Also included are safety controls: Overload protection for motors, high and low refrigerant pressure switches and a solid state lock-out control circuit. Unit finish coated galvalume. Optional UL approved internal electric heater, factory installed with primary thermal overload protection and magnetic contactors; internal loop pump; and internal heat recovery package (208/230-1-60 only).

Minimum entering fluid temperature with fresh water is 45°F. For lower temperatures, GeoMaster recommends antifreeze protection to at least 20°F below the lowest EFT.

GeoMaster, LLC  
3512 Cavalier Drive  
Fort Wayne, IN 46808  
877-443-6411  
www.geoexcel.com



PACKAGE UNITS

# SPECIFICATION DATA SHEET

LOOP GROUP HIGH-EFFICIENCY WATER SOURCE HEAT PUMPS

# GT062

## ELECTRICAL SPECIFICATIONS

Electrical Characteristics	Elect. Symbol	Compressor		Blower		Loop Pump*		Min. Circuit Amps	Max. Fuse Size
		RLA	LRA	FLA	HP	FLA	HP		
208/230-1-60	-1	25.6	169.0	5.0	3/4	1.75	1/6	38.8	60
208/230-3-60	-3	17.7	123.0	5.0	3/4	-	-	27.3	45
460-3-60	-4	9.0	49.5	2.5	3/4	-	-	13.8	20
575-3-60	-5	7.2	40.0	2.6	3/4	-	-	11.6	15

\* Loop pump is a factory installed option on 208/230-1-60 units only.

## MECHANICAL SPECIFICATIONS

Evaporator			
Square Feet	Rows Deep	Tube Size (O.D.)	Fins Per Inch
4.5	3	3/8	14
Blower Size	Weight		
	Net	Ship	
11x9	376	402	

## BLOWER PERFORMANCE

Available External Static Pressure (Inches of Water, Gauge. Wet coil and Filter Included)												
Blower Speed	0.10	0.20	0.30	0.40	0.50	0.60	0.70	0.80	0.90	1.00	1.10	1.20
High	2160	2100	2030	1950	1870	1800	1730	1680	1640	1600	1550	1500
Medium	2110	2050	1990	1900	1820	1750	1690	1650	1600	1550	-	-
Low	2060	2000	1950	1850	1760	1700	1640	1580	-	-	-	-

## CONDENSER WATER FLOW

Water Flow (GPM)	Press. Drop (FOH)
6.0	1.7
8.0	3.0
10.0	4.8
15.0	10.8
18.0	15.5
22.0	23.2

## ISO 13256-1 PERFORMANCE DATA Rated at 2000 CFM and 15.0 GPM

Water Loop				Ground Water				Ground Loop			
Cooling		Heating		Cooling		Heating		Cooling		Heating	
Capacity	EER	Capacity	COP	Capacity	EER	Capacity	COP	Capacity	EER	Capacity	COP
60000	12.5	77000	4.5	65000	17.5	60000	4.0	60500	14.0	48000	3.2



## CAPACITY DATA

All performance at 2000 CFM and 15.0 GPM

### COOLING EFT Range 45°F to 110°F

Entering Fluid Temp.	Ent. Air Wet Bulb Temp.	Total Capacity BTUH	Watts Input	Heat Rejection BTUH	Sensible Capacity BTUH			EER
					75°	80°	85°	
50°	61°	64541	3306	75821	49116	58926	64541	19.5
	64°	67670	3379	79200	45948	58332	64693	20.0
	67°	70852	3453	82634	42299	55265	63767	20.5
	70°	74086	3527	86121	35265	48749	63418	21.0
	73°	77373	3602	89664	-	41549	56947	21.5
60°	61°	62463	3592	74719	47534	57028	62463	17.4
	64°	65491	3672	78019	44468	56453	62609	17.8
	67°	68570	3752	81372	40936	53485	61713	18.3
	70°	71700	3833	84777	34129	47179	61375	18.7
	73°	74881	3914	88236	-	40211	55113	19.1
70°	61°	59508	3882	72755	45286	54331	59508	15.3
	64°	62393	3968	75933	42365	53783	59648	15.7
	67°	65327	4055	79163	39000	50955	58794	16.1
	70°	68309	4142	82442	32515	44947	58473	16.5
	73°	71340	4230	85773	-	38309	52506	16.9
85°	61°	52354	4389	67330	39841	47799	52354	11.9
	64°	54892	4487	70200	37271	47317	52476	12.2
	67°	57473	4585	73115	34311	44829	51725	12.5
	70°	60096	4683	76075	28606	39543	51442	12.8
	73°	62762	4782	79080	-	33703	46193	13.1
100°	61°	44277	4859	60855	33695	40425	44277	9.1
	64°	46423	4967	63369	31521	40017	44381	9.3
	67°	48606	5075	65922	29018	37913	43745	9.6
	70°	50825	5184	68513	24193	33443	43506	9.8
	73°	53080	5294	71143	-	28504	39067	10.0

### HEATING EFT Range 25°F to 80°F

Entering Fluid Temp.	Dry Bulb	Heating Capacity BTUH	Heat of Absorb. BTUH	Power Input Watts	COP
50°	60°	68837	52345	4834	4.2
	70°	65293	48489	4925	3.9
	80°	61127	43972	5028	3.6
60°	60°	77095	59930	5031	4.5
	80°	68460	50605	5233	3.8
70°	60°	85218	67262	5263	4.7
	80°	80830	62535	5362	4.4
80°	60°	75673	56995	5474	4.1
	70°	93251	74535	5485	5.0
	80°	88450	69380	5589	4.6
		82807	63339	5706	4.3



Units are complete packages containing refrigeration compressor, reversing valve, expansion valve metering device and water to refrigerant heat exchanger. Also included are safety controls: Overload protection for motors, high and low refrigerant pressure switches and a solid state lock-out control circuit. Unit finish coated galvalume. Optional UL approved internal electric heater, factory installed with primary thermal overload protection and magnetic contactors; internal loop pump; and internal heat recovery package (208/230-1-60 only).

Minimum entering fluid temperature with fresh water is 45°F. For lower temperatures, GeoMaster recommends antifreeze protection to at least 20°F below the lowest EFT.

GeoMaster, LLC  
3512 Cavalier Drive  
Fort Wayne, IN 46808  
877-443-6411  
www.geoexcel.com



PACKAGE UNITS

# SPECIFICATION DATA SHEET

LOOP GROUP HIGH-EFFICIENCY WATER SOURCE HEAT PUMPS

# GT070

## ELECTRICAL SPECIFICATIONS

Electrical Characteristics	Elect. Symbol	Compressor		Blower		Loop Pump*		Min. Circuit Amps	Max. Fuse Size
		RLA	LRA	FLA	HP	FLA	HP		
2208/230-1-60	-1	28.8	169.0	5.0	3/4	1.75	1/6	42.8	70
208/230-3-60	-3	19.1	123.0	5.0	3/4	-	-	29.1	45
460-3-60	-4	9.1	62.0	2.5	3/4	-	-	13.9	20
575-3-60	-5	7.2	50.0	2.6	3/4	-	-	11.6	15

\* Loop pump is a factory installed option on 208/230-1-60 units only.

## MECHANICAL SPECIFICATIONS

Evaporator			
Square Feet	Rows Deep	Tube Size (O.D.)	Fins Per Inch
4.5	3	3/8	14
Blower Size	Weight		
	Net	Ship	
11x9	376	402	

## BLOWER PERFORMANCE

Available External Static Pressure (Inches of Water, Gauge. Wet coil and Filter Included)												
Motor Speed	0.10	0.20	0.30	0.40	0.50	0.60	0.70	0.80	0.90	1.00	1.10	1.20
High	2260	2229	2202	2177	2139	2093	2040	1977	1917	1855	1790	1729
Medium	2180	2150	2125	2090	2051	2006	1957	1903	1844	1781	1700	-
Low	2130	2102	2075	2035	1992	1946	1888	1832	1763	1702	-	-

## CONDENSER WATER FLOW

Water Flow (GPM)	Press. Drop (FOH)
6.0	1.7
8.0	3.0
10.0	4.8
15.0	10.8
18.0	15.5
22.0	23.2

## ISO 13256-1 PERFORMANCE DATA Rated at 2200 CFM and 16.0 GPM

Water Loop				Ground Water				Ground Loop			
Cooling		Heating		Cooling		Heating		Cooling		Heating	
Capacity	EER	Capacity	COP	Capacity	EER	Capacity	COP	Capacity	EER	Capacity	COP
68000	12.5	82000	4.6	76000	18.7	66000	3.8	69000	13.9	53000	3.4



## CAPACITY DATA

All performance at 2200 CFM and 16.0 GPM

### COOLING EFT Range 45°F to 110°F

Entering Fluid Temp.	Ent. Air Wet Bulb Temp.	Total Capacity BTUH	Watts Input	Heat Rejection BTUH	Sensible Capacity BTUH			EER
					75°	80°	85°	
50°	61°	72322	3552	84441	55037	66030	72322	20.4
	64°	75828	3631	88216	51487	65364	72491	20.9
	67°	79393	3710	92052	47398	61927	71454	21.4
	70°	83017	3790	95948	39516	54625	71063	21.9
	73°	86700	3870	99905	-	46558	63812	22.4
60°	61°	68833	3987	82435	52382	62844	68833	17.3
	64°	72170	4075	86074	49003	62210	68994	17.7
	67°	75563	4164	89771	45111	58939	68007	18.1
	70°	79012	4254	93526	37610	51990	67635	18.6
	73°	82518	4344	97339	-	44312	60733	19.0
70°	61°	65344	4407	80380	49727	59659	65344	14.8
	64°	68512	4505	83882	46519	59057	65497	15.2
	67°	71733	4603	87438	42825	55952	64560	15.6
	70°	75008	4702	91051	35704	49355	64206	16.0
	73°	78335	4802	94719	-	42066	57655	16.3
85°	61°	60111	5052	77347	45744	54881	60111	11.9
	64°	63025	5164	80643	42794	54327	60252	12.2
	67°	65988	5277	83991	39395	51471	59389	12.5
	70°	69000	5390	87391	32844	45402	59064	12.8
	73°	72062	5504	90842	-	38697	53037	13.1
100°	61°	54877	5697	74314	41762	50103	54877	9.6
	64°	57538	5823	77405	39068	49598	55006	9.9
	67°	60243	5950	80544	35965	46990	54219	10.1
	70°	62993	6078	83731	29985	41449	53922	10.4
	73°	65788	6207	86966	-	35328	48420	10.6

### HEATING EFT Range 25°F to 80°F

Entering Fluid Temp.	Dry Bulb	Heating Capacity BTUH	Heat of Absorb. BTUH	Power Input Watts	COP
50°	60°	71053	53124	5255	4.0
	70°	67395	49127	5354	3.7
	80°	63095	44446	5466	3.4
60°	60°	79733	61047	5477	4.3
	80°	75628	56589	5580	4.0
70°	60°	88413	68970	5698	4.5
	80°	83861	64051	5806	4.2
80°	60°	78510	58287	5927	3.9
	70°	97093	76893	5920	4.8
	80°	92094	71513	6032	4.5
	80°	86218	65207	6158	4.1



Units are complete packages containing refrigeration compressor, reversing valve, expansion valve metering device and water to refrigerant heat exchanger. Also included are safety controls: Overload protection for motors, high and low refrigerant pressure switches and a solid state lock-out control circuit. Unit finish coated galvalume. Optional UL approved internal electric heater, factory installed with primary thermal overload protection and magnetic contactors; internal loop pump; and internal heat recovery package (208/230-1-60 only).

Minimum entering fluid temperature with fresh water is 45°F. For lower temperatures, GeoMaster recommends antifreeze protection to at least 20°F below the lowest EFT.

GeoMaster, LLC  
 3512 Cavalier Drive  
 Fort Wayne, IN 46808  
 877-443-6411  
 www.geoexcel.com



GT-SERIES, 3/4 - 6 TON

# LOW TEMP HEATING PERFORMANCE

LOOP GROUP HIGH-EFFICIENCY WATER SOURCE HEAT PUMPS, GEO-THERMAL SERIES

Model Number	Entering Fluid Temp.	Dry Bulb	Heating Capacity BTUH	Heat of Absorb. BTUH	Power Input Watts	COP
<b>GT010</b> 2.5 GPM 350 CFM	25°	60°	7,674	5,739	567	4.0
		70°	7,279	5,307	578	3.7
		80°	6,815	4,801	590	3.4
	30°	60°	8,222	6,156	606	4.0
		70°	7,799	5,694	617	3.7
		80°	7,301	5,152	630	3.4
	40°	60°	9,277	6,976	674	4.0
		70°	8,799	6,455	687	3.8
		80°	8,238	5,845	701	3.4
<b>GT018</b> 4.0 GPM 550 CFM	25°	60°	10,822	7,698	916	3.5
		70°	10,265	7,082	933	3.2
		80°	9,610	6,360	952	3.0
	30°	60°	11,746	8,581	927	3.7
		70°	11,141	7,917	945	3.5
		80°	10,430	7,138	965	3.2
	40°	60°	13,638	10,387	953	4.2
		70°	12,936	9,623	971	3.9
		80°	12,111	8,728	991	3.6
<b>GT024</b> 5.0 GPM 800 CFM	25°	60°	17,657	12,172	1,608	3.2
		70°	16,748	11,159	1,638	3.0
		80°	15,680	9,974	1,672	2.7
	30°	60°	19,170	13,567	1,642	3.4
		70°	18,183	12,475	1,673	3.2
		80°	17,023	11,195	1,708	2.9
	40°	60°	22,194	16,357	1,711	3.8
		70°	21,051	15,104	1,743	3.5
		80°	19,708	13,637	1,779	3.2
<b>GT030</b> 7.5 GPM 1000 CFM	25°	60°	17,610	12,473	1,506	3.4
		70°	16,703	11,469	1,534	3.2
		80°	15,637	10,294	1,566	2.9
	30°	60°	19,612	14,368	1,537	3.7
		70°	18,602	13,259	1,566	3.5
		80°	17,415	11,961	1,599	3.2
	40°	60°	23,617	18,155	1,601	4.3
		70°	22,401	16,836	1,631	4.0
		80°	20,972	15,290	1,665	3.7
<b>GT036</b> 9.0 GPM 1200 CFM	25°	60°	23,335	16,199	2,091	3.3
		70°	22,133	14,862	2,131	3.0
		80°	20,721	13,298	2,176	2.8
	30°	60°	25,558	18,315	2,123	3.5
		70°	24,242	16,862	2,163	3.3
		80°	22,696	15,161	2,208	3.0
	40°	60°	30,005	22,544	2,187	4.0
		70°	28,460	20,858	2,228	3.7
		80°	26,644	18,884	2,275	3.4

Model Number	Entering Fluid Temp.	Dry Bulb	Heating Capacity BTUH	Heat of Absorb. BTUH	Power Input Watts	COP
<b>GT042</b> 9.0 GPM 1400 CFM	25°	60°	27,989	19,838	2,389	3.4
		70°	26,548	18,243	2,434	3.2
		80°	24,854	16,376	2,485	2.9
	30°	60°	30,624	22,356	2,423	3.7
		70°	29,047	20,623	2,469	3.4
		80°	27,194	18,594	2,521	3.2
	40°	60°	35,893	27,391	2,492	4.2
		70°	34,045	25,382	2,539	3.9
		80°	31,873	23,029	2,592	3.6
<b>GT048</b> 12.0 GPM 1600 CFM	25°	60°	34,162	24,022	2,972	3.4
		70°	32,403	22,071	3,028	3.1
		80°	30,335	19,788	3,091	2.9
	30°	60°	37,270	26,950	3,025	3.6
		70°	35,352	24,836	3,082	3.4
		80°	33,096	22,361	3,146	3.1
	40°	60°	43,488	32,806	3,131	4.1
		70°	41,249	30,365	3,190	3.8
		80°	38,617	27,506	3,257	3.5
<b>GT054</b> 14.0 GPM 1800 CFM	25°	60°	40,318	28,159	3,564	3.3
		70°	38,242	25,853	3,631	3.1
		80°	35,802	23,154	3,707	2.8
	30°	60°	43,523	31,133	3,631	3.5
		70°	41,282	28,658	3,700	3.3
		80°	38,648	25,760	3,777	3.0
	40°	60°	50,051	37,205	3,765	3.9
		70°	47,474	34,386	3,836	3.6
		80°	44,445	31,083	3,916	3.3
<b>GT062</b> 15.0 GPM 2000 CFM	25°	60°	46,636	32,069	4,269	3.2
		70°	44,235	29,393	4,350	3.0
		80°	41,413	26,260	4,441	2.7
	30°	60°	51,082	36,086	4,395	3.4
		70°	48,452	33,173	4,478	3.2
		80°	45,361	29,763	4,572	2.9
	40°	60°	59,434	43,698	4,612	3.8
		70°	56,374	40,341	4,699	3.5
		80°	52,777	36,409	4,797	3.2
<b>GT070</b> 16.0 GPM 2200 CFM	25°	60°	49,354	33,317	4,700	3.1
		70°	46,813	30,473	4,789	2.9
		80°	43,826	27,145	4,889	2.6
	30°	60°	53,694	37,278	4,811	3.3
		70°	50,929	34,203	4,902	3.0
		80°	47,680	30,605	5,004	2.8
	40°	60°	62,373	45,201	5,033	3.6
		70°	59,162	41,665	5,128	3.4
		80°	55,387	37,525	5,235	3.1

Minimum entering fluid temperature with fresh water is 45°F (7.2°C). The above ratings are based on the use of a solution of 15% methanol and 85% water by weight. GeoMaster, LLC recommends antifreeze protection to at least 20°F (11°C) below the lowest entering fluid temperature. Coefficients of Performance do not include a pumping power penalty.

Note: Published fluid side pressure drop tables are based on 70° (21°C) fresh water. When designing the system, pressure drop should be modified for antifreeze content and fluid temperature. GeoMaster, LLC recommends adding 0.2% to the system pressure drop for every 1°F (0.36% / 1°C) below 70°F (21°C) in addition to any antifreeze correction factors.

# Operating Temperatures & Pressures, GT010-024

			OPERATING DATA								
			COOLING				HEATING				
Model	Entering Water Temp., °F	Water Flow GPM	Suction Pressure PSIG	Discharge Pressure PSIG	Water Temp. Rise, °F	Air Temp. Drop, °F	Suction Pressure PSIG	Discharge Pressure PSIG	Water Temp. Drop, °F	Air Temp. Rise, °F	
GT010	30°	1.5					40-44	167-184	6-7	17-19	
		4.0					46-51	171-189	3-4	19-21	
	40°	1.5	75-83	113-125	18-20	19-22	48-53	181-200	6-8	20-22	
		4.0	75-83	87-96	8-9	20-22	55-61	185-205	3-4	22-24	
	50°	1.5	78-86	132-146	18-19	19-21	57-63	193-213	9-10	22-24	
		4.0	78-86	102-112	8-9	19-21	66-73	198-218	4-5	24-27	
	60°	1.5	80-88	153-169	17-19	18-20	68-75	204-225	11-12	25-27	
		4.0	80-88	118-130	8-8	19-21	78-86	209-231	5-6	27-30	
	70°	1.5	81-89	179-198	17-18	18-20	80-88	215-238	12-13	27-30	
		4.0	81-89	138-153	7-8	18-20	91-101	220-244	6-7	30-33	
	80°	1.5	83-91	207-228	16-18	17-19	91-101	227-251	14-15	30-34	
		4.0	83-91	159-176	7-8	18-19	105-116	233-257	7-8	34-37	
	90°	1.5	84-92	237-262	16-17	17-18	100-111	236-261	16-18	34-37	
		4.0	84-92	183-202	7-8	17-19	114-127	242-268	8-9	37-41	
	100°	1.5	85-93	267-295	15-17	16-17					
		4.0	85-93	206-227	6-7	16-18					
	GT018	30°	2.0					40-44	158-175	7-8	14-16
			4.0					44-49	162-179	3-4	15-17
40°		2.0	75-83	119-132	20-22	21-23	44-49	168-185	8-9	17-18	
		4.0	75-83	96-106	10-11	21-23	49-55	171-189	4-5	18-20	
50°		2.0	76-84	135-149	20-22	20-22	49-54	177-196	9-10	19-21	
		4.0	76-84	109-120	10-11	21-23	54-60	181-200	5-6	21-23	
60°		2.0	78-86	157-174	19-21	20-22	57-63	186-206	10-12	22-24	
		4.0	78-86	127-140	10-11	20-22	64-71	190-210	5-6	24-26	
70°		2.0	79-87	181-200	18-20	19-21	67-74	196-216	12-14	25-27	
		4.0	79-87	146-162	9-10	19-22	75-83	200-221	7-8	27-30	
80°		2.0	80-88	210-232	18-20	19-21	78-86	206-227	14-16	27-30	
		4.0	80-88	170-188	9-10	19-21	87-96	210-232	8-9	29-33	
90°		2.0	82-90	238-263	18-20	18-20	86-95	220-243	16-18	30-33	
		4.0	82-90	192-213	9-10	18-20	96-106	224-248	9-10	32-36	
100°		2.0	84-92	269-298	17-19	17-19					
		4.0	84-92	217-240	9-10	18-20					
GT024		30°	3.0					36-42	170-180	5-6	19-23
			8.0					40-45	180-190	2-3	20-24
	40°	3.0	74-79	143-153	21-25	18-23	45-50	190-200	7-8	21-25	
		8.0	73-78	133-143	11-12	18-23	50-55	200-210	3-4	22-26	
	50°	3.0	75-80	153-163	21-25	18-23	54-58	210-220	11-12	23-27	
		8.0	74-79	143-153	11-12	18-23	58-62	220-225	5-6	24-29	
	60°	3.0	75-80	163-173	21-24	18-22	63-66	225-230	11-12	27-32	
		8.0	74-79	153-163	10-11	18-23	66-72	230-235	6-7	29-34	
	70°	3.0	76-81	190-200	20-24	18-23	70-74	235-245	11-12	30-35	
		8.0	75-80	180-190	10-11	17-22	75-80	245-255	7-8	31-37	
	80°	3.0	77-82	200-210	20-24	17-22	80-85	255-265	12-13	33-39	
		8.0	76-81	190-200	10-11	16-21	85-90	265-275	8-9	34-40	
	90°	3.0	78-83	220-230	20-23	16-21	90-95	275-285	13-14	36-42	
		8.0	77-82	210-220	9-10	16-21	95-100	285-295	9-10	38-44	
	100°	3.0	79-84	240-250	20-23	15-20					
		8.0	78-83	230-240	9-10	14-19					

This chart shows approximate temperatures and pressures for a unit in good repair. The values shown are meant as a guide only and should not be used to estimate system charge. This chart assumes rated air flow and 80° d.b./67° w.b. entering air temperature in cooling, 70° d.b. entering air temperature in heating. Heating data at entering fluid temperatures below 50° assumes the use of antifreeze.

As a result of continuing research and development, specifications are subject to change without notice.



GeoMaster, LLC  
 3512 Cavalier Drive  
 Fort Wayne, IN 46808  
 877-443-6411  
 www.geoexcel.com  
 PTIP6.P65

REV: 1-02

# Operating Temperatures & Pressures, GT030-042

			OPERATING DATA								
			COOLING				HEATING				
Model	Entering Water Temp., °F	Water Flow GPM	Suction Pressure PSIG	Discharge Pressure PSIG	Water Temp. Rise, °F	Air Temp. Drop, °F	Suction Pressure PSIG	Discharge Pressure PSIG	Water Temp. Drop, °F	Air Temp. Rise, °F	
GT030	30°	4.0					37-43	184-192	5-6	20-24	
		8.0					40-45	193-203	2-3	21-26	
	40°	4.0	70-74	122-129	22-24	19-24	44-48	205-216	6-7	23-27	
		8.0	69-73	112-119	10-11	19-24	46-50	217-225	4-5	23-28	
	50°	4.0	71-75	132-139	22-24	19-24	50-54	226-234	8-9	24-29	
		8.0	70-74	122-129	10-11	19-24	54-64	235-245	5-6	24-29	
	60°	4.0	72-76	152-159	22-24	19-24	62-67	246-252	11-12	27-32	
		8.0	71-75	142-149	10-11	19-24	67-73	253-261	6-7	29-34	
	70°	4.0	73-77	186-189	22-24	18-23	73-77	262-266	11-12	31-36	
		8.0	72-76	176-186	10-11	18-23	77-82	267-277	7-8	33-40	
	80°	4.0	74-78	196-199	22-24	18-23	82-86	277-286	12-13	34-41	
		8.0	73-77	186-189	10-11	18-23	86-90	287-291	8-9	36-42	
	90°	4.0	75-79	226-229	21-23	17-22	92-96	291-296	12-13	38-44	
		8.0	74-78	206-209	9-10	17-22	96-102	296-301	8-9	40-46	
	100°	4.0	76-78	256-259	21-23	17-22					
		8.0	75-79	236-239	9-10	16-21					
	GT036	30°	5.0					37-44	178-194	5-6	20-24
			9.0					41-46	184-202	2-3	21-26
40°		5.0	70-74	122-130	18-21	19-24	45-49	186-203	6-7	23-27	
		9.0	69-73	116-120	10-11	19-24	49-53	192-209	4-5	23-28	
50°		5.0	72-76	132-139	18-21	19-24	58-62	195-215	8-9	24-29	
		9.0	70-74	125-129	10-11	19-24	62-65	201-224	5-6	24-29	
60°		5.0	74-78	152-160	17-20	19-24	68-71	215-230	10-11	27-32	
		9.0	73-77	144-151	9-10	18-23	72-76	222-238	6-7	29-34	
70°		5.0	75-79	172-180	17-20	18-23	78-83	235-245	10-11	31-36	
		9.0	74-78	166-172	9-10	18-23	82-87	241-252	6-7	33-40	
80°		5.0	76-80	182-190	17-20	17-22	87-90	246-257	11-12	34-41	
		9.0	75-79	187-182	9-10	17-22	90-94	252-263	7-8	36-42	
90°		5.0	77-80	202-210	17-20	17-22	95-99	258-276	12-13	38-44	
		9.0	76-79	190-200	9-10	17-22	99-104	262-282	8-9	40-46	
100°		5.0	78-81	233-250	16-19	17-22					
		9.0	77-80	211-240	8-9	16-22					
GT042		30°	6.0					36-42	172-180	5-6	16-20
			9.0					40-45	182-190	3-4	17-22
	40°	6.0	68-74	133-141	23-25	19-23	45-50	192-200	6-7	18-23	
		9.0	67-73	108-126	10-11	19-23	50-55	202-210	4-5	19-24	
	50°	6.0	69-75	153-161	23-25	19-23	54-58	212-220	8-9	20-25	
		9.0	68-74	130-135	10-11	19-23	58-68	200-230	5-6	22-27	
	60°	6.0	74-79	178-186	22-24	19-23	62-70	226-234	11-12	23-28	
		9.0	73-78	152-160	10-11	18-22	70-74	234-242	6-7	25-30	
	70°	6.0	76-81	192-202	21-25	18-22	74-77	242-248	11-12	28-32	
		9.0	75-80	176-186	9-10	18-22	77-82	251-261	7-8	30-34	
	80°	6.0	77-81	218-230	21-23	17-21	82-88	262-268	12-13	31-36	
		9.0	76-80	198-210	9-10	17-21	88-93	266-278	8-9	33-38	
	90°	6.0	78-82	242-254	21-23	17-21	94-99	276-280	13-14	34-39	
		9.0	77-81	222-234	9-10	16-20	99-104	282-294	9-10	35-41	
	100°	6.0	78-82	266-278	21-23	15-19					
		9.0	77-81	246-258	9-10	14-18					

This chart shows approximate temperatures and pressures for a unit in good repair. The values shown are meant as a guide only and should not be used to estimate system charge. This chart assumes rated air flow and 80° d.b./67° w.b. entering air temperature in cooling, 70° d.b. entering air temperature in heating. Heating data at entering fluid temperatures below 50° assumes the use of antifreeze.

As a result of continuing research and development, specifications are subject to change without notice.



GeoMaster, LLC  
 3512 Cavalier Drive  
 Fort Wayne, IN 46808  
 877-443-6411  
 www.geoexcel.com  
 PTIP6.P65

REV: 1-02

# Operating Temperatures & Pressures, GT048-062

			OPERATING DATA								
			COOLING				HEATING				
Model	Entering Water Temp., °F	Water Flow GPM	Suction Pressure PSIG	Discharge Pressure PSIG	Water Temp. Rise, °F	Air Temp. Drop, °F	Suction Pressure PSIG	Discharge Pressure PSIG	Water Temp. Drop, °F	Air Temp. Rise, °F	
GT048	30°	6.0					31-38	175-214	3-4	14-17	
		12.0					35-42	183-223	2-3	15-18	
	40°	6.0	66-80	117-143	17-21	20-24	39-48	193-236	6-7	17-21	
		12.0	66-80	105-128	9-11	20-25	44-54	201-246	3-4	18-22	
	50°	6.0	68-83	136-167	18-21	19-23	48-58	211-258	8-10	20-24	
		12.0	68-83	122-149	9-11	19-24	53-65	220-269	4-5	22-26	
	60°	6.0	69-84	161-196	17-21	18-22	56-68	225-275	9-11	23-28	
		12.0	69-84	144-176	9-11	19-23	63-77	234-286	5-6	25-31	
	70°	6.0	69-84	185-226	18-21	18-22	66-80	230-281	13-16	29-35	
		12.0	69-84	166-203	9-11	18-22	74-90	240-293	7-9	31-38	
	80°	6.0	69-85	214-262	17-21	17-21	76-93	248-303	15-19	32-40	
		12.0	69-85	192-235	9-11	18-21	85-104	258-316	8-10	35-43	
	90°	6.0	71-87	243-297	17-20	16-20	87-106	264-322	17-21	36-44	
		12.0	71-87	219-267	8-10	17-21	97-119	275-336	9-11	39-48	
	100°	6.0	71-87	273-333	17-20	17-20					
		12.0	71-87	245-299	8-10	17-21					
	GT054	30°	8.0					33-41	167-204	3-4	18-22
			18.0					37-45	173-212	2-3	19-24
40°		8.0	66-80	117-143	13-16	21-26	42-52	184-225	5-6	22-27	
		18.0	66-80	107-131	7-9	22-27	47-57	191-233	3-4	24-29	
50°		8.0	68-83	137-167	13-16	20-25	51-63	201-246	7-9	27-32	
		18.0	68-83	125-152	7-9	21-25	57-69	209-255	4-5	28-35	
60°		8.0	69-84	161-197	13-16	20-24	60-74	214-262	8-10	31-38	
		18.0	69-84	147-180	7-9	20-24	67-82	222-271	5-6	33-40	
70°		8.0	70-86	178-218	13-16	20-24	72-88	229-280	10-12	34-42	
		18.0	70-86	162-198	7-9	20-24	79-97	238-290	6-7	37-45	
80°		8.0	71-87	206-252	12-15	19-23	83-101	247-302	11-14	39-47	
		18.0	71-87	188-230	7-8	19-23	91-111	256-313	7-8	42-51	
90°		8.0	73-89	235-287	12-15	18-22	94-115	263-321	12-15	43-53	
		18.0	73-89	214-261	7-8	18-23	104-127	272-333	7-9	46-56	
100°		8.0	73-89	263-321	12-15	18-22					
		18.0	73-89	239-292	7-8	19-23					
GT062		30°	10.0					31-38	169-206	3-4	19-23
			20.0					34-41	174-213	2-3	20-25
	40°	10.0	61-74	115-141	13-16	22-27	39-48	186-227	6-7	23-28	
		20.0	61-74	106-129	8-9	22-27	43-52	192-235	3-4	25-30	
	50°	10.0	62-76	134-164	14-17	21-25	47-58	203-248	8-10	28-34	
		20.0	62-76	123-150	8-10	21-26	52-64	210-257	5-6	29-36	
	60°	10.0	63-77	158-193	13-16	20-24	56-68	216-264	9-11	32-39	
		20.0	63-77	145-177	8-9	20-25	61-75	224-273	6-7	34-42	
	70°	10.0	63-77	177-217	14-17	19-24	66-81	228-278	11-13	35-43	
		20.0	63-77	163-199	8-10	20-24	73-89	235-287	6-8	37-46	
	80°	10.0	64-78	206-251	13-16	18-23	76-93	245-300	12-15	40-49	
		20.0	64-78	188-230	8-9	19-23	84-102	254-310	7-9	42-52	
	90°	10.0	65-80	234-285	13-16	18-22	87-106	261-319	14-17	44-54	
		20.0	65-80	214-262	7-9	18-22	95-117	270-329	8-10	47-57	
	100°	10.0	66-80	262-320	13-16	18-22					
		20.0	66-80	240-293	7-9	18-22					

This chart shows approximate temperatures and pressures for a unit in good repair. The values shown are meant as a guide only and should not be used to estimate system charge. This chart assumes rated air flow and 80° d.b./67° w.b. entering air temperature in cooling, 70° d.b. entering air temperature in heating. Heating data at entering fluid temperatures below 50° assumes the use of antifreeze.



GeoMaster, LLC  
 3512 Cavalier Drive  
 Fort Wayne, IN 46808  
 877-443-6411  
 www.geoexcel.com  
 PTIP6.P65

As a result of continuing research and development, specifications are subject to change without notice.

REV: 1-02

# Operating Temperatures & Pressures, GT070

			OPERATING DATA								
			COOLING				HEATING				
Model	Entering Water Temp., °F	Water Flow GPM	Suction Pressure PSIG	Discharge Pressure PSIG	Water Temp. Rise, °F	Air Temp. Drop, °F	Suction Pressure PSIG	Discharge Pressure PSIG	Water Temp. Drop, °F	Air Temp. Rise, °F	
GT070	30°	12.0					31-38	169-206	3-4	19-23	
		22.0					34-41	174-213	2-3	20-25	
	40°	12.0	61-74	115-141	13-16	22-27	39-48	186-227	6-7	23-28	
		22.0	61-74	106-129	8-9	22-27	43-52	192-235	3-4	25-30	
	50°	12.0	62-76	134-164	14-17	21-25	47-58	203-248	8-10	28-34	
		22.0	62-76	123-150	8-10	21-26	52-64	210-257	5-6	29-36	
	60°	12.0	63-77	158-193	13-16	20-24	56-68	216-264	9-11	32-39	
		22.0	63-77	145-177	8-9	20-25	61-75	224-273	6-7	34-42	
	70°	12.0	63-77	177-217	14-17	19-24	66-81	228-278	11-13	35-43	
		22.0	63-77	163-199	8-10	20-24	73-89	235-287	6-8	37-46	
	80°	12.0	64-78	206-251	13-16	18-23	76-93	245-300	12-15	40-49	
		22.0	64-78	188-230	8-9	19-23	84-102	254-310	7-9	42-52	
	90°	12.0	65-80	234-285	13-16	18-22	87-106	261-319	14-17	44-54	
		22.0	65-80	214-262	7-9	18-22	95-117	270-329	8-10	47-57	
	100°	12.0	66-80	262-320	13-16	18-22					
		22.0	66-80	240-293	7-9	18-22					
		30°									
		40°									
50°											
60°											
70°											
80°											
90°											
100°											
	30°										
	40°										
	50°										
	60°										
	70°										
	80°										
	90°										
	100°										

This chart shows approximate temperatures and pressures for a unit in good repair. The values shown are meant as a guide only and should not be used to estimate system charge. This chart assumes rated air flow and 80° d.b./67° w.b. entering air temperature in cooling, 70° d.b. entering air temperature in heating. Heating data at entering fluid temperatures below 50° assumes the use of antifreeze.

As a result of continuing research and development, specifications are subject to change without notice.



GeoMaster, LLC  
 3512 Cavalier Drive  
 Fort Wayne, IN 46808  
 877-443-6411  
[www.geoexcel.com](http://www.geoexcel.com)  
 PTIP6.P65

REV: 1-02